

GAP: 1200min. – 1500 max. (1500mm preferred)

Minimum height of bollards 0.8m

PLAN

TYPE A – BOLLARDS

TO BE USED WHERE VEHICULAR ACCESS IS TO BE RESTRICTED

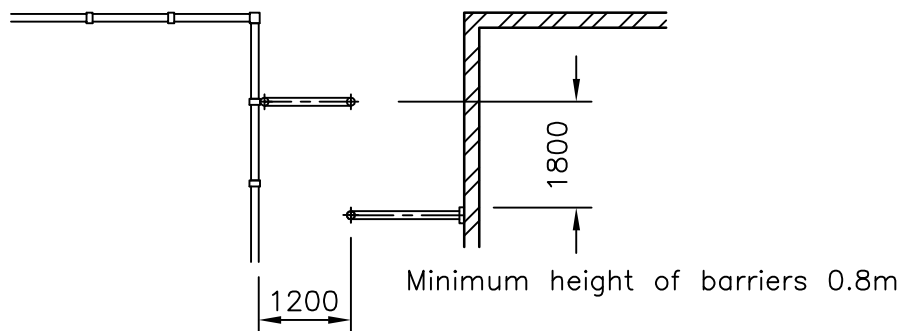

PLAN

TYPE B – CHICANE

TO BE USED WHERE WALKWAYS LINK WITH FOOTPATHS

NOTE:

Rails to be made from 50mm ϕ medium wall thickness galvanised tube and then white powder coated.



MANUKAU
City Council

DETAIL:

ACCESS BARRIERS

Engineering
Quality
Standards

DETAIL No:
R22

MANUKAU CITY COUNCIL

UPDATED:
FEB 2006