

Radius:

1. 10m for carriageway width <12.2m (Residential)
2. 12m for carriageway width >12.2m (Industrial)

\* Dimension as per table on R5

**PLAN – Unsignalised Intersections**

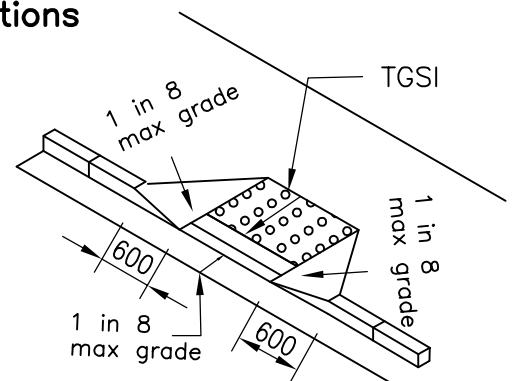
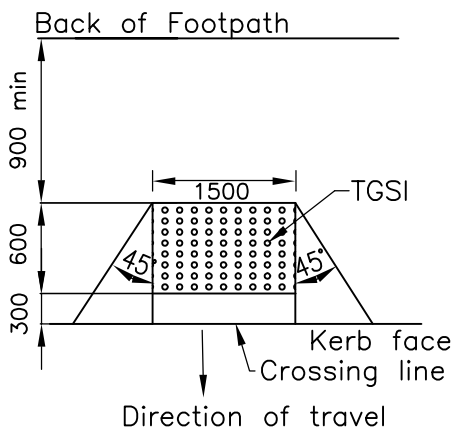

**SURFACE FINISH TO KERB RAMPS**

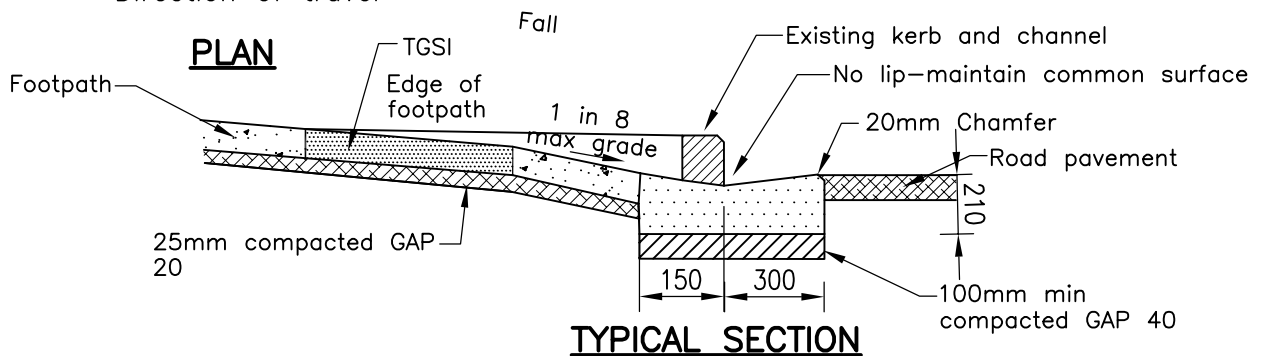

**Notes:**

1. All concrete to be 20MPa, constructed in accordance with NZS 3109 with U3 broom finish to NZS 3114.
2. Tactile ground surface indicators shall be yellow in colour, manufactured and installed in accordance with AS/NZS 1428.4 and LTNZ RTS 14.
3. Tactile ground surface indicators to extend full width of drop section and to be aligned with direction of travel.
4. Catchpits shall be located a minimum of 1m clear upstream of pram crossings.



DETAIL:

**PRAM CROSSING**

Engineering  
Quality  
Standards

DETAIL No:  
**R8**

**MANUKAU CITY COUNCIL**

UPDATED:  
**FEB 2007**