

TRANSITION KERBSTONE

(BETWEEN OLD AND NEW KERBS)  
 300MM WIDE (TAPERING TO  
 180MM WIDE) x 600MM LONG x  
 200MM DEEP  
 BASALT G3027  
 (HAND POINTED FINISH)

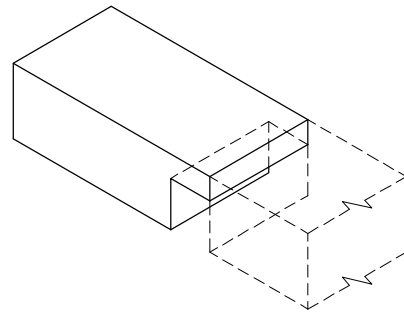

DOWNPIPE DISCHARGE  
 KERBSTONE

300MM WIDE x 600MM LONG  
 x 200MM DEEP WITH 120MM  
 x 135MM REBATE  
 BASALT G3027  
 (HAND POINTED FINISH)

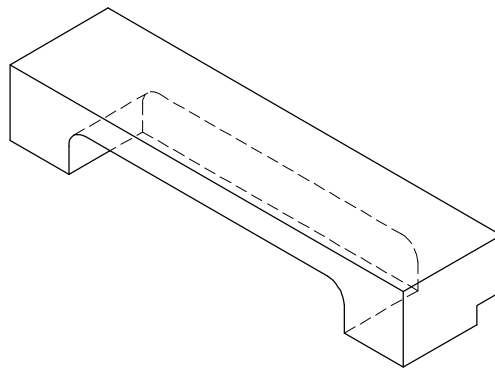

CATCHPIT LINTEL

300MM WIDE x 1200MM LONG x 200MM  
 DEEP WITH TEXT ETCHED ON THE TOP FACE  
 (REFER TO SHEET 2008/1106)  
 BASALT G3027  
 (HAND POINTED FINISH)

(DIMENSIONS TO BE PROVIDED AND  
 CONFIRMED BY ENGINEER)

PREPARED BY OPUS:



**AUCKLAND CITY**  
 Transport

QUEEN STREET  
 PAVING AND KERB TYPES  
 SHEET FOUR OF FIVE

SCALE : NTS

DRAWN : MKG

ISSUE DATE : 11/2008

APPROVED : 

PLAN No. ISSUE B

2008/1104