

ALSO REFER TO DRAWINGS
2008/0419, 2008/0420
AND 2008/0422.

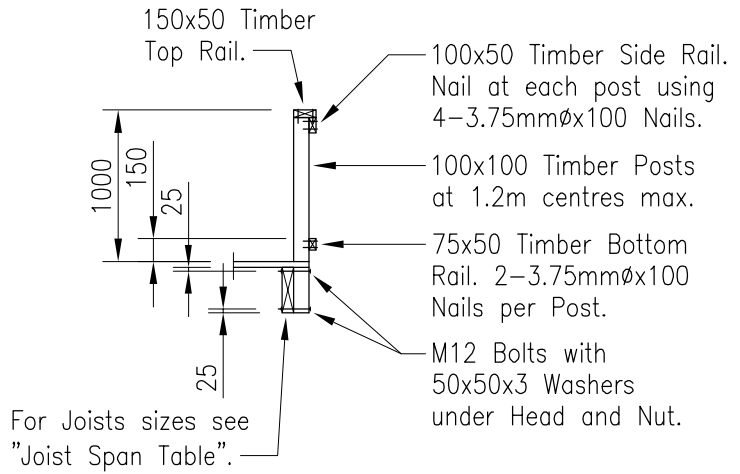

BALUSTRADE DETAIL

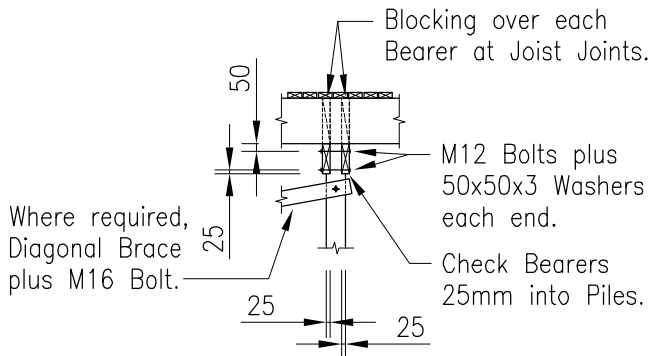

**DETAIL 1
BEARER/PILE DETAIL**

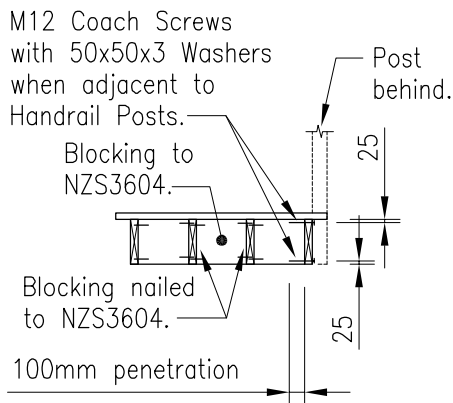

SECTION A - A

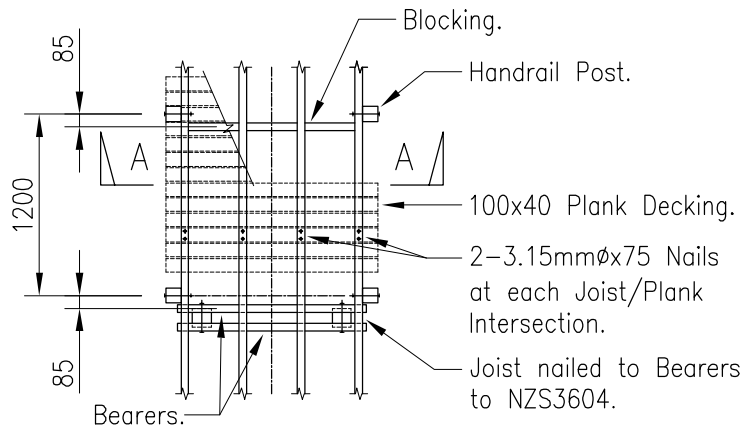

**PART PLAN
BELOW DECKING**

PREPARED BY OPUS:



AUCKLAND CITY
Transport

BOARDWALK
SECTIONS AND DETAILS

SCALE :	NTS
DRAWN :	MKG
ISSUE DATE :	11/2008
APPROVED :	
PLAN No.	ISSUE B
2008/0421	