

SURFACE PATCHING

STRUCTURAL PATCHING

NB: These drawings illustrate the minimum requirements of Council. The contractor may elect to use superior alternatives with the approval of the Engineer.

** Where full depth repairs are required the subgrade CBR is to be tested and pavement depth design approved by The Engineer.

All repairs to be finished flush with the existing road surface.

If the edge of the repair is within 1 metre of a construction joint, a crack or the edge of existing pavement, then the existing pavement within this zone is to be replaced as part of the repair reinstatement. All joints to be sealed.



HAURAKI GULF ISLANDS

In the Hauraki Gulf Islands all road surfacing is to be reinstated to match the existing surrounding surface.

GRANULAR
300mm DEPTH
** (Deeper if required)

** Geogrid reinforcing if required and as directed by Engineer

** Geotextile as required

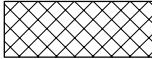
-  ASPHALTIC CONCRETE TO MATCH EXISTING
-  TNZ M4 AP40 BITUMINOUS EMULSION MIX / OR TNZ M4 AP40 BASECOURSE
-  APPROVED SUBBASE GAP65

ALL WORK TO COMPLY WITH TNZ STANDARDS



PREPARED BY OPUS:

PAVEMENT REPAIRS

SCALE:	NTS
DRAWN:	JZW
ISSUE DATE:	11/2008
APPROVED:	
PLAN No.	2008/0108 Issue B